

## General Description:

此液晶驱动 IC, 含 LCD 的控制线路, 搭配 MCU 来使用, 将使使用者的成本降低, 以及应用更加宽广。

## Features:

- 工作电压 2.4V-5.5V
- 系统频率:
  - 内建 RC 振荡器(256Khz)
  - 外挂 32768Hz 晶振
  - 外灌 256Khz 输入 (由 OSCI 脚)
- 提供简单 3pins 串接接口(CKRB/CKWB/DIO)
- 提供 Buzzer 驱动功能
- 提供 Time base 和 watch dog timer 功能
- 提供 VLCD 脚, 可以调整 LCD 的电压
- 提供驱动 32 SEG/4 COM
- 液晶驱动 duty 可以选择 1/2 duty, 1/3 duty 或是 1/4 duty
- 液晶驱动 bias 可以选择 1/2 bias 或是 1/3 bias
- 提供内部 RESET 线路
- 提供 24-SOP/28-SOP/48-SSOP/48-LQFP 封装

## Application:

- \* 液晶驱动控制器
- \* 运动器材显示
- \* DVD 播放器
- \* DVR 播放器
- \* VCD 播放器
- \* Car Display
- \* 音响 Display
- \* 仪表 LCD 显示
- \* 小家电 LCD 显示
- \* 通讯产品
- \* 工业控制 LCD 显示
- \* MCU+LCD Driver
- \* LCD 模组
- \* 电磁炉 LCD 显示

## Pin Assignment

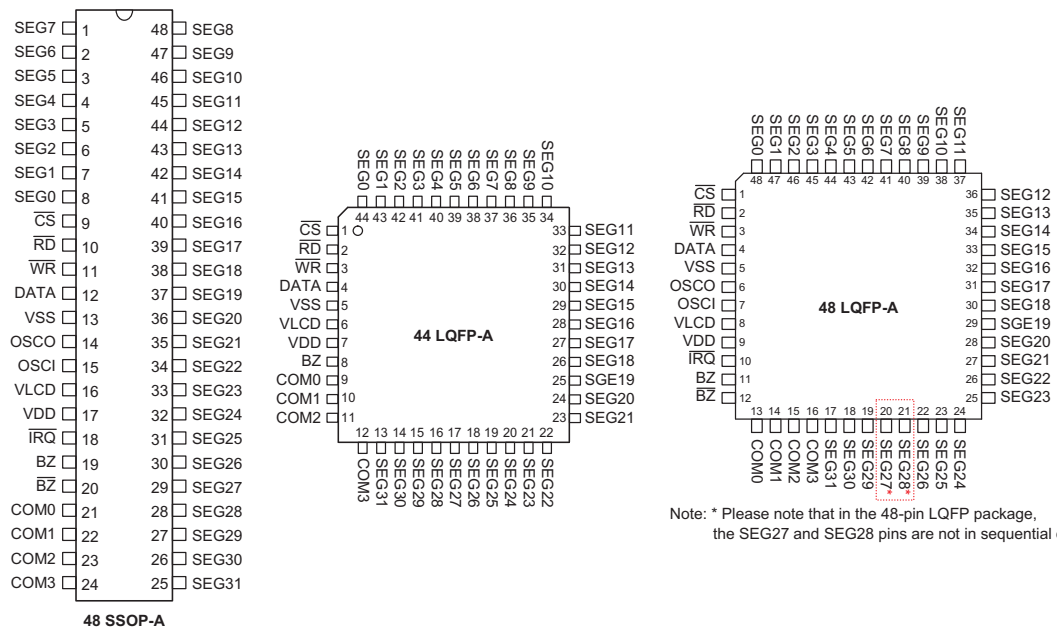

Note: \* Please note that in the 48-pin LQFP package, the SEG27 and SEG28 pins are not in sequential order.

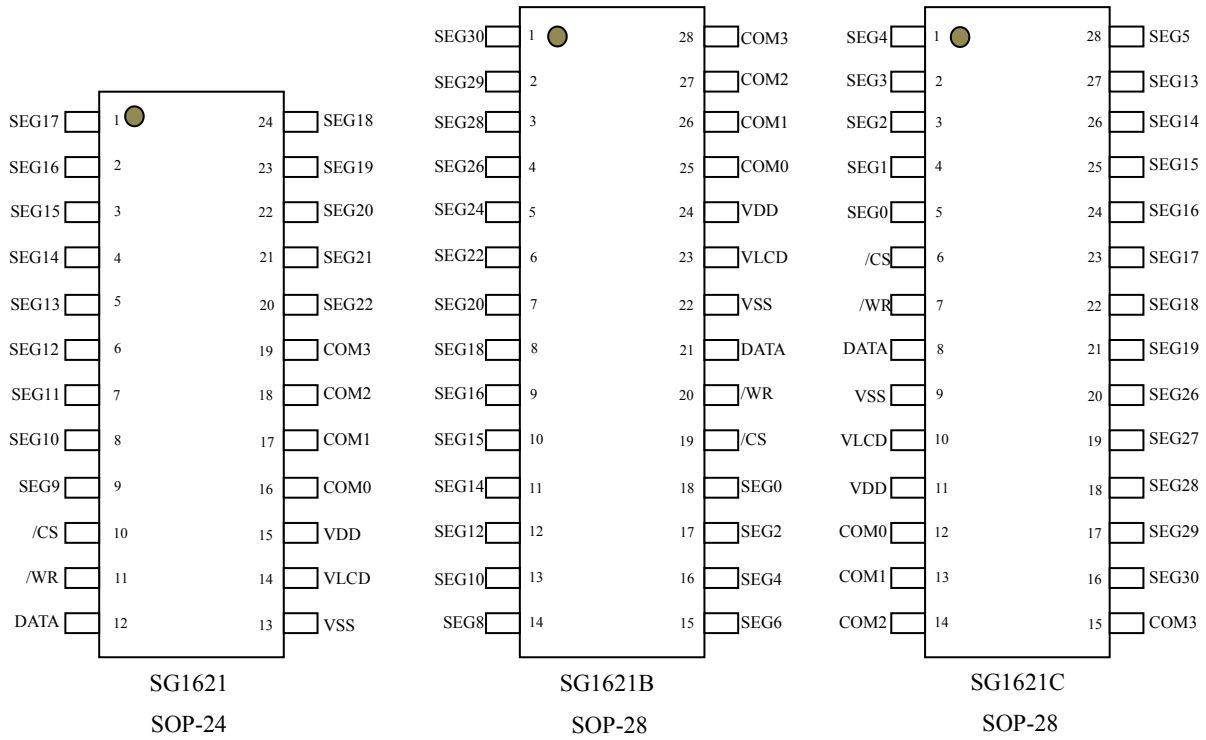

## .PAD Location

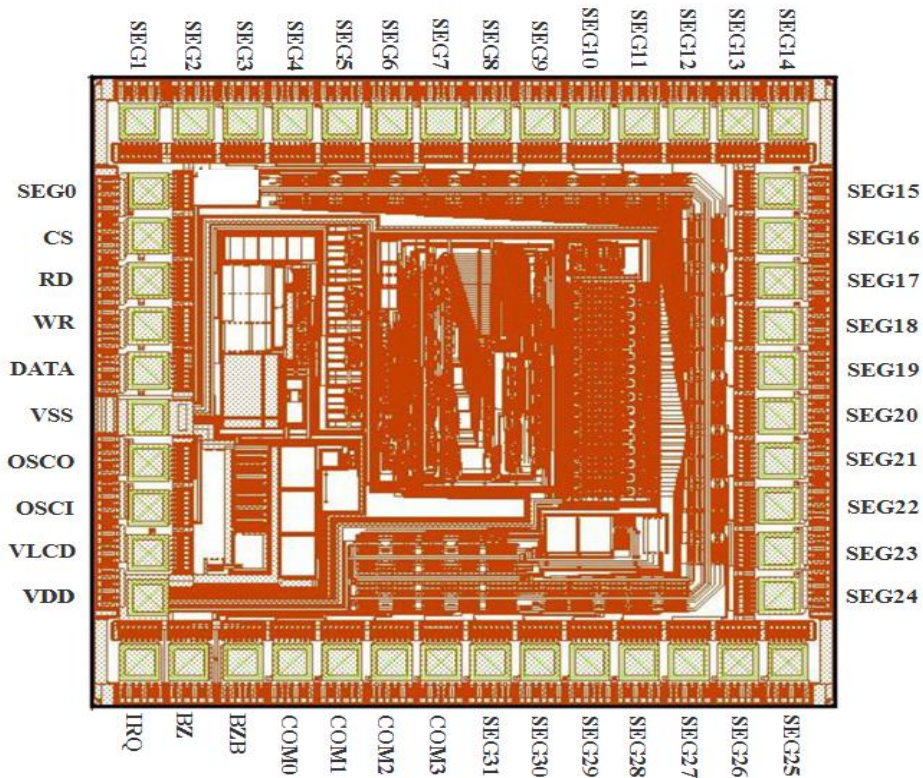

Chip size: 1185um x 1265um  
 SUBSTRATE floating(recommend) or VDD

序号	名称	X 坐标	Y 坐标	序号	名称	X 坐标	Y 坐标
1	CS	282.75	90.6	26	SEG22	762.75	1109.4
2	RD	362.75	90.6	27	SEG21	682.75	1109.4
3	WR	442.75	90.6	28	SEG20	602.75	1109.4
4	DATA	522.75	90.6	29	SEG19	522.75	1109.4
5	VSS	605.6	90.6	30	SEG18	442.75	1109.4
6	OSCO	686.3	90.6	31	SEG17	362.75	1109.4
7	OSCI	766.3	90.6	32	SEG16	282.75	1109.4
8	VLCD	846.3	90.6	33	SEG15	202.75	1109.4
9	VDD	926.3	90.6	34	SEG14	79.1	1123.5
10	IRQ	1040.9	76.5	35	SEG13	79.1	1043.5
11	BZ	1040.9	156.5	36	SEG12	79.1	963.5
12	BZB	1040.9	243.5	37	SEG11	79.1	883.5
13	COM0	1040.9	323.5	38	SEG10	79.1	803.5
14	COM1	1040.9	403.5	39	SEG9	79.1	723.5
15	COM2	1040.9	483.5	40	SEG8	79.1	643.5
16	COM3	1040.9	563.5	41	SEG7	79.1	563.5
17	SEG31	1040.9	643.5	42	SEG6	79.1	483.5
18	SEG30	1040.9	723.5	43	SEG5	79.1	403.5
19	SEG29	1040.9	803.5	44	SEG4	79.1	323.5
20	SEG28	1040.9	883.5	45	SEG3	79.1	243.5
21	SEG27	1040.9	963.5	45	SEG2	79.1	163.5
22	SEG26	1040.9	1043.5	47	SEG1	79.1	76.5
23	SEG25	1040.9	1123.5	48	SEG0	202.75	90.6
24	SEG24	922.75	1109.4				
25	SEG23	842.75	1109.4				

**Pin Description**

Name	I/O	Description
RD	I	串接输入控制脚, low active, 有 pull high 电阻 50Kohm@3V
WR	I	串接输入控制脚, low active, 有 pull high 电阻 50Kohm@3V
DATA	I/O	串接输入/输出数据脚, 有 pull high 电阻 50Kohm@3V
GND	P	电源负端

VLCD	P	LCD 电源端
VDD	P	电源正端
COMO-COM3	O	LCD common 脚
SEG31-0	O	LCD segment 脚
CSB	I	内建 pull high 电阻, 当 CS 为选辑时, 资料 及指令始能接收
BZ/BZB	O	Buzzer 驱动输出脚
IRQ	O	Timer 输出脚, NMO S open drain
OSCI	I	32768Hz 晶振接脚或 是外频输入脚 256Khz
OSCO	O	32768 晶振接脚

**AC/DC Characteristics**
**1 Absolutely max. ratings**

ITEM	SYMBOL	RATING	UNIT
Operating Temperature	Top	-20°- +70°	°C
Storage Temperature	Tsto	-50°C - +125°C	°C
Supply Voltage	VDD	5.5	V
Voltage to input terminal	Vin	Vss-0.3 to Vdd+0.3	V

**2 D.C.Characteristics**

Item	Symbol	Condition	Typ	Min	Max	unit	
Operating voltage	VDD		2.4	3	5.5	V	
Power consumption current	LOPR1	3v	Internal RC oscillator on, LCD On, no load		150	300	uA
		5v		300	620		
Power consumption current	LOPR2	3v	Internal RC oscillator on, LCD Off, no load		40	80	uA
		5v		100	200		
Power consumption current	LOPR3	3v	External Crystal oscillator on, LCD on, no load		90	125	uA
		5v		160	250		
stand by current	Ist	3v	System halt, No load, Oscillator off, LCD off		1	2	V
		5v		2	5		
Input low voltage for input pin	VIL1	3v	CKRB/CKWB/DIO	0		0.6	V
		5v		0	1.0		
Input low voltage for input pin	VIH1	3v	CKRB/CKWB/DIO	2.4		3	uA
		5v		4.0	5		
Segment output 'H'	ISOH	3v		-100	-150		uA
		5v		-200	-300		
Segment output 'L'	ISOL	3v		60	120		uA
		5v		120	200		
Common output 'H'	ICOH	3v		-100	-150		uA
		5v		-200	-300		
Common output 'L'	ICOL	3v		200	250		uA
		5v		400	500		

**3 A.C.Characteristics**

Item	Symbol	Condition	Min	Typ	Max	unit
System clock	f <sub>SYS</sub>	RC oscillator @3V(256Khz)		256		KHz
LCD frame frequency	F <sub>LCD1</sub>	1/2 duty		64		HZ
	F <sub>LCD2</sub>	1/3 duty		86		
	F <sub>LCD3</sub>	1/4 duty		64		
串行控制 CKWB	F <sub>CKWB</sub>	@3V, Clock duty 50%			150	Khz
		@5V, Clock duty 50%			300	
串行控制 CKRB	F <sub>CKRB</sub>	@3V, Clock duty 50%			75	Khz
		@5V, Clock duty 50%			150	
串行控制 SYNCB	TSYNCB	@3V		250	75	ns

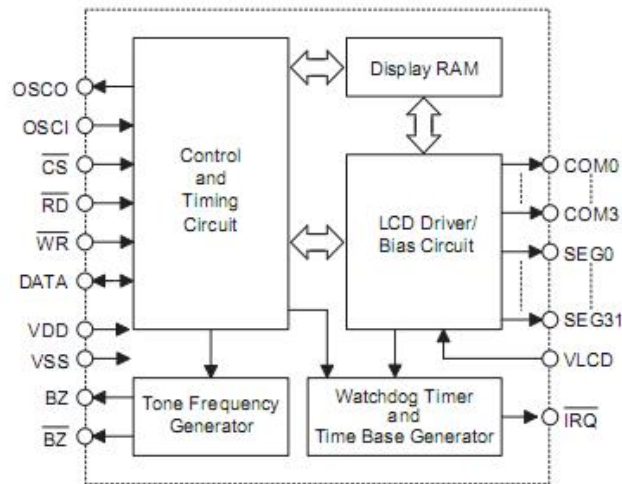
**Block Diagram**

Note:  $\overline{CS}$ : Chip selection  
 $BZ, \overline{BZ}$ : Tone outputs  
 $\overline{WR}, \overline{RD}, DATA$ : Serial interface  
 $COM0\sim COM3, SEG0\sim SEG31$ : LCD outputs  
 $IRQ$ : Time base or WDT overflow output

**Function Description**
**1 控制格式表**

功能	前置码	Mode Code	句柄	
			地址码	资料码
指令	1	00	C7C6C5C4—C3C2C1C0--x	
写入	1	01	x-A4A3A2A1A0	BOB1B2B3
读取	1	10	x-A4A3A2A1A0	B0A1A2A3

功能	功能	句柄	功能描述	Initial State
		C7C6C5C4-C3C2C1C0-x		
系统	RTC	0001-01xx-x	选择系统频率 32768Hz crystal	
	INOSC	0001-10xx-x	选择系统频率内部 RC 振荡器 (256Khz)	V
	EXOSC	0001-11xx-x	选择系统频率外部 clock input (256Khz)	

初始 设定	L2B2D	0010-00x0-x	选择 1/2 bias, 1/2 duty	
	L2B3D	0010-01x0-x	选择 1/2 bias, 1/3duty	
	L2B4D	0010-10x0-x	选择 1/2 bias, 1/4duty	
	L3B2D	0010-00x1-x	选择 1/3 bias,1/2 duty	
	L3B3D	0010-01x1-x	选择 1/3 bias,1/3 duty	
	L3B4D	0010-10x1-x	选择 1/3 bias,1/4 duty	
	BZ4K	010x-xxxx-x	选择 buzzer frequency 为 4Khz	
	BZ2K	011x-xxxx-x	选择 buzzer frequency 为 2Khz	
系 统 控 制	SysOff	0000-0000-x	系统振荡器 OFF & LCD 电路 OFF	V
	SysOn	0000-0001-x	系统振荡器 ON	
	LCDoff	0000-0010-x	LCD 电路 OFF	V
	LCDon	0000-0011-x	LCD 电路 ON	
	BZdis	0000-1000-x	关闭 Buzzer 输出	V
	BZen	0000-1001-x	打开 Buzzer 输出	
	TMOdis	100x-0xxx-x	关闭 TMO 输出	V
	TMOen	100x-1xxx-x	打开 TMO 输出	
勿 用	No used	1110-0000-x	请勿使用	
	Defanlt	1110-0011-x	初始值	V

功能	功能	句柄 C7C6C5C4 - C3C2C1C0-x	功能描述	Initial State	
T M O 频 率 系 统 控 制	TMS	0000-01DE-X			
		DE=00	TM1 off		
		DE=01	TM2 off		
		DE=10	TM1 on		
		DE=11	TM2 on		
	RTM1	0000-11xx-x	Reset TM1 Counter		
	RTM12	0000-111x-x	Reset TM2 Counter		
	TMP	101x-xABC-X	TM1 on (pulse output)	TM2 on (one shot output)	
		ABC=000	TMO=1HZ	TMO=0 after 4s	
		ABC=001	TMO=2HZ	TMO=0 after 2s	
		ABC=010	TMO=4HZ	TMO=0 after 1s	
		ABC=011	TMO=8HZ	TMO=0 after 500ms	
		ABC=100	TMO=16HZ	TMO=0 after 250ms	
		ABC=101	TMO=32HZ	TMO=0 after 125ms	
		ABC=110	TMO=64HZ	TMO=0 after 62.5ms	
		ABC=111	TMO=128HZ	TMO=0 after 31.25ms	

\* 请注意 TMO 有 PULSE 输出 (8 个 system clock 宽度) 和 EDGE 输出两种



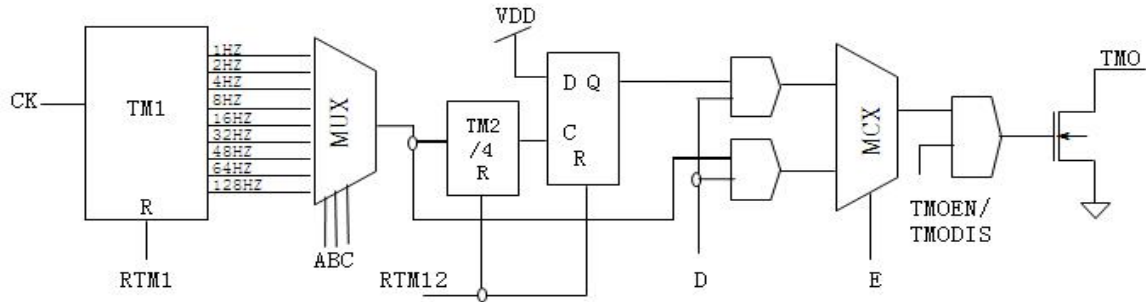

## 2 建议使用步骤

- A. 先做【系统初始设定】，如上表。例如：设定 LCD 的 Biss 和 Duty，如果没有使用 Buzzer 输出，就不用对 BZ2K 或是 BZ4K 做设定。
- B. 如果有用 TMO 功能，请做好【TMO 频率控制选择】设定和选择【TM1】pulse output 或是【TM2】one shot output，如果没有使用，则忽略此项设定，直接跳至下一项。
- C. 设定 LCD RAM 的初始值。
- D. 设定【SysOn】，以启动振荡器。
- E. 设定【LCDOn】，此时 LCD display 会 show 出 LCD 初始显示。
- F. 设定【SysOff】时，可以同时关掉振荡器和 LCD 显示，此时的【LCDOn】的 register，不会被清掉，还会保留下来，所以下一次设定【SysOn】后，可以同时打开振荡器和 LCD 显示。
- G. 设定【LCDoff】时，可以只关掉 LCD 显示。

## 3 LCD RAM 位置

A4A3A2A1A0	COM0	COM1	COM2	COM3
	Bit0	Bit1	Bit2	Bit2
00H			SEG0	
01H			SEG1	
02H			SEG2	
03H			SEG3	
04H			SEG4	
05H			SEG5	
06H			SEG6	
07H			SEG7	
08H			SEG8	
09H			SEG9	
0AH			SEG10	
0BH			SEG11	
0CH			SEG12	
0DH			SEG13	
0EH			SEG14	
0FH			SEG15	
10H			SEG16	
11H			SEG17	
12H			SEG18	
13H			SEG19	
14H			SEG20	
15H			SEG21	

16H	SEG22
17H	SEG23
18H	SEG24
19H	SEG25
1AH	SEG26
1BH	SEG27
1CH	SEG28
1DH	SEG29
1EH	SEG30
1FH	SEG31

时序图:

a. READ 模式 (指令码: 110)

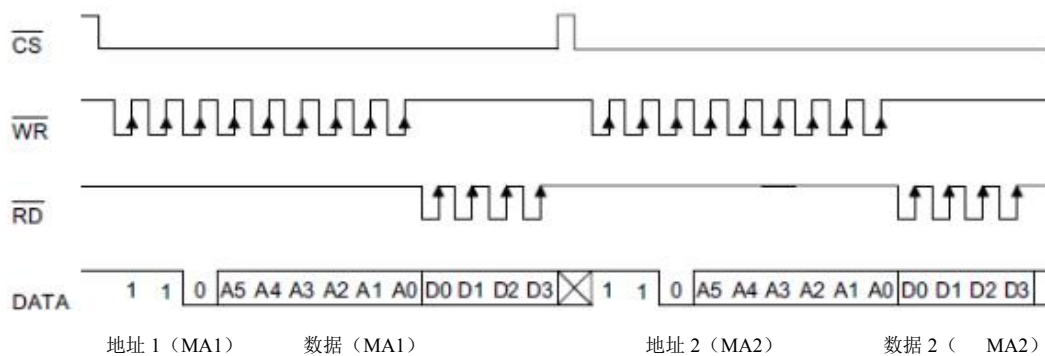

b. READ 模式 (连续地址读)

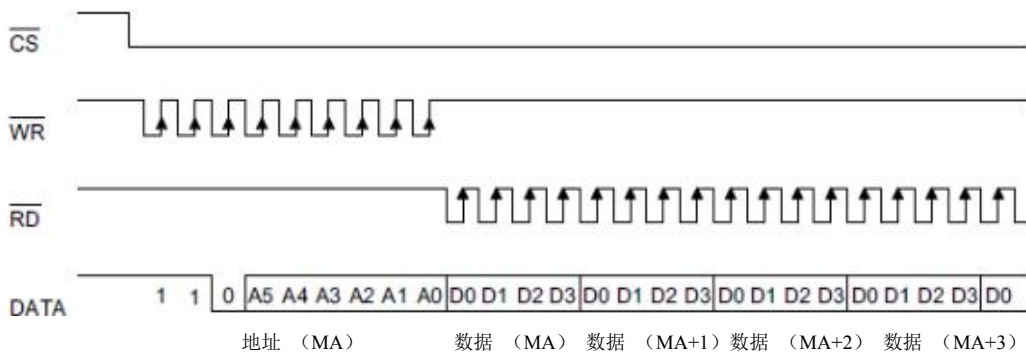

c. WRITE 模式 (指令码: 101)

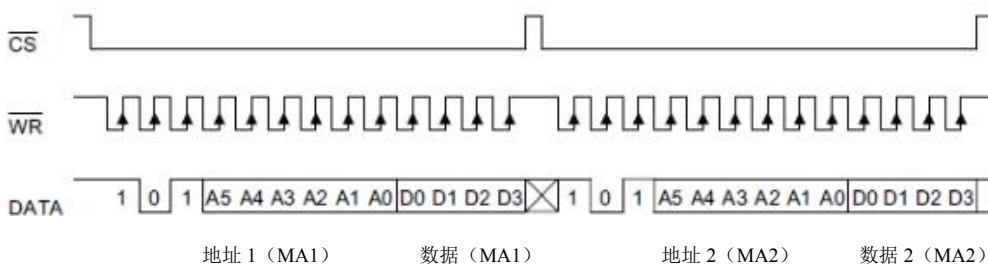



d. WRITE 模式（连续地址写）

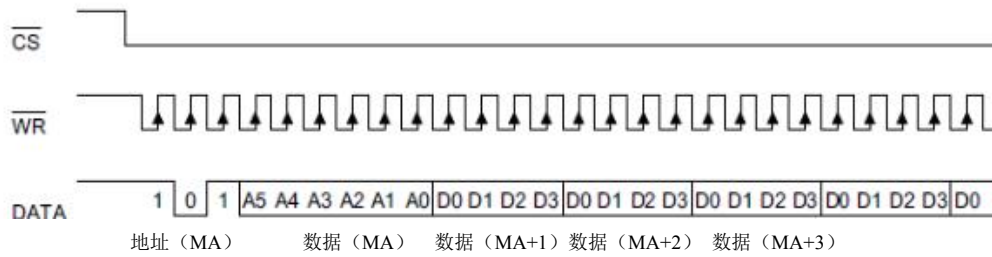

e. READ—MODIFY—WRITE 模式（指令码： 101）

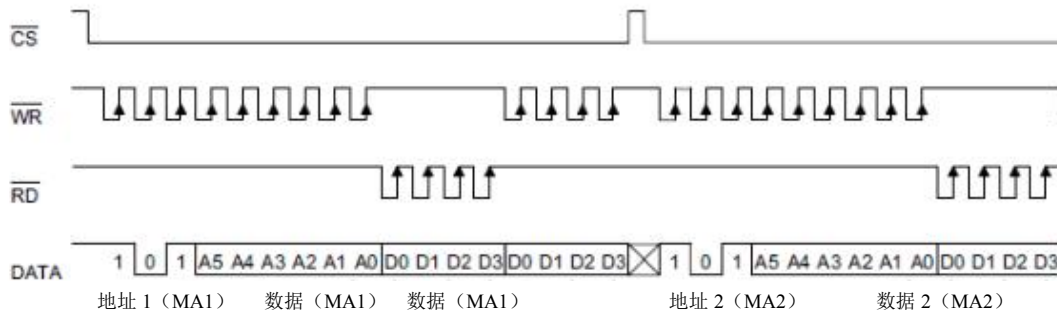

f. READ—MODIFY—WRITE 模式（连续地址存取）

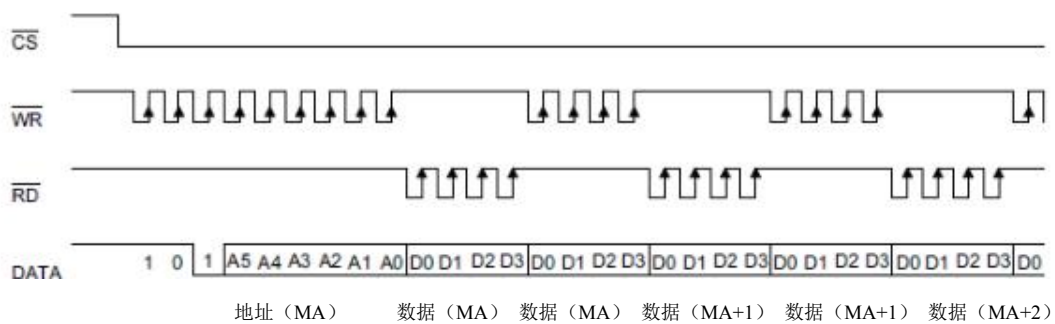

Application circuit

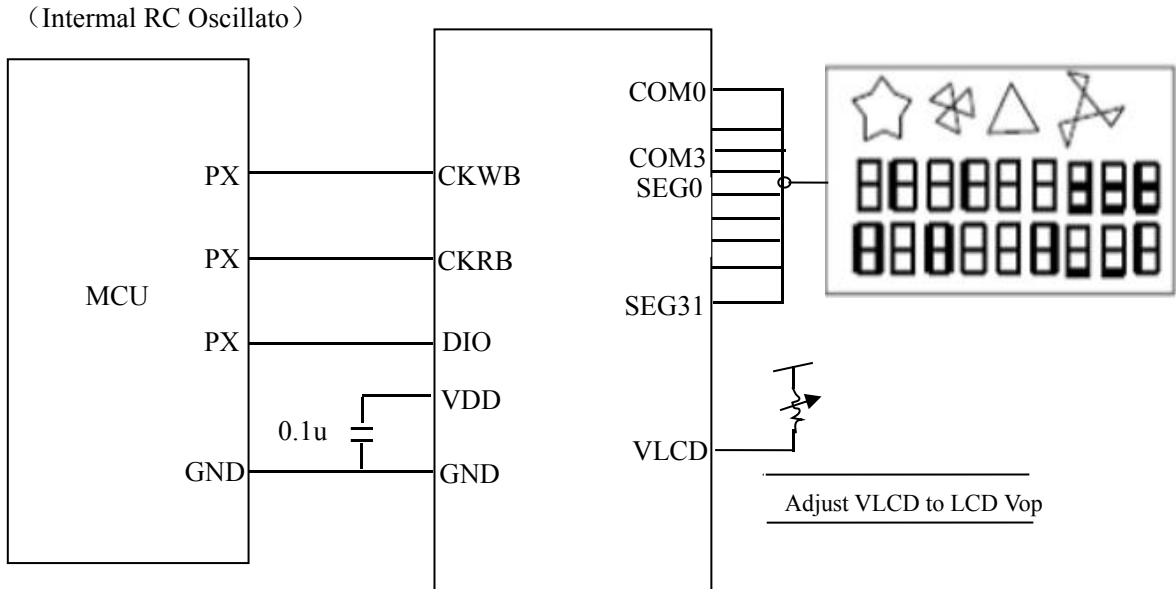

LCD324-4

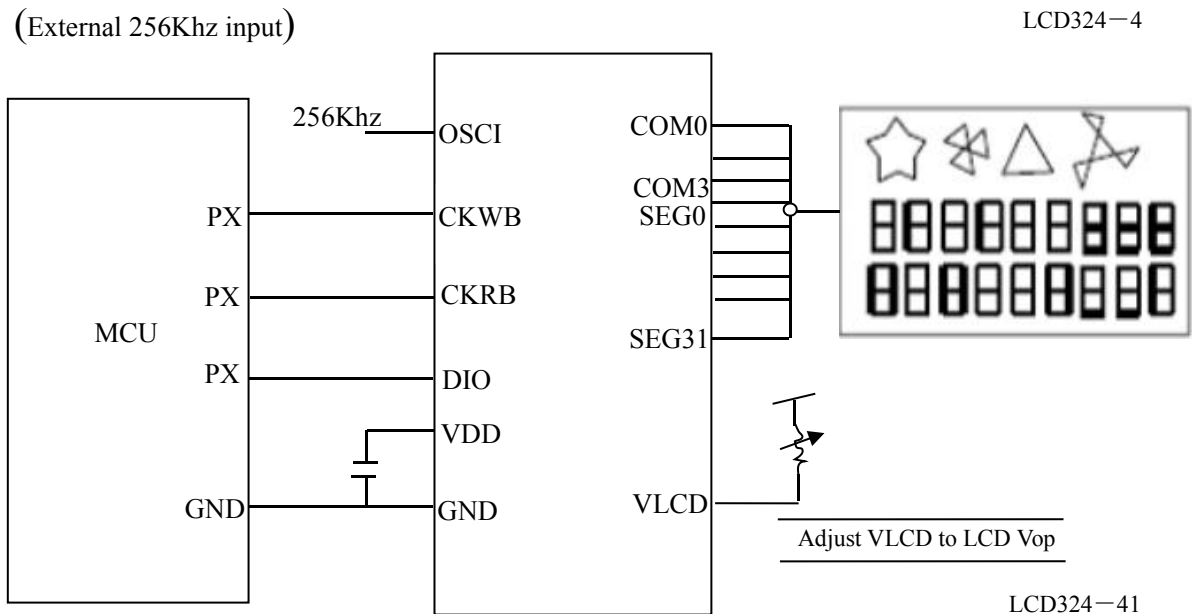

LCD324-41

External 32768Hz Crystal oscillator)

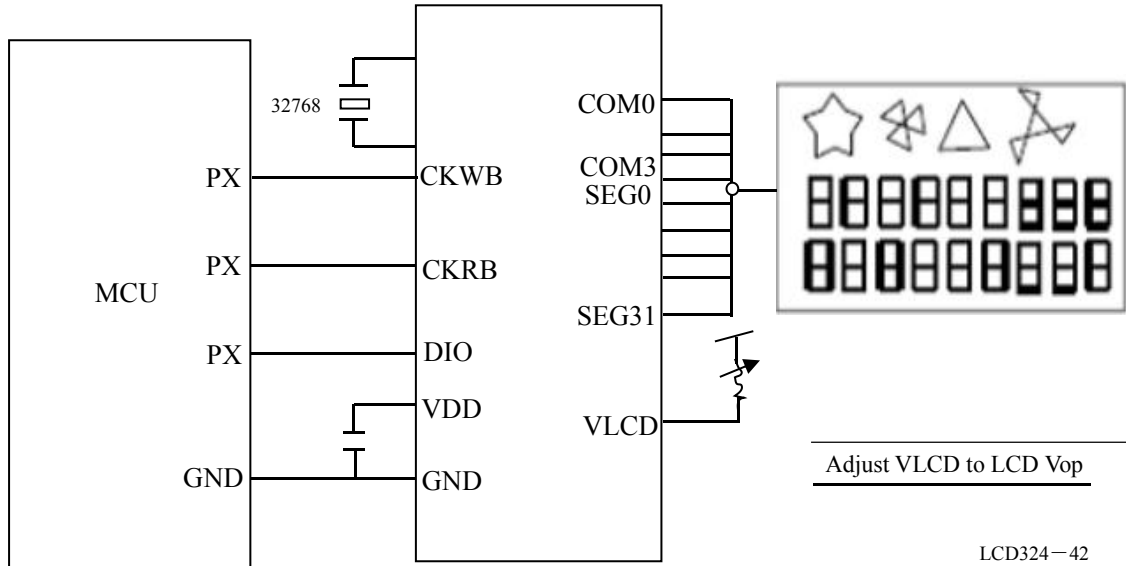

VR 建议值:

- 在 VDD=5V 时, VLCD=3V, VR=24k ohm
- 在 VDD=5V 时, VLCD=4.5V, VR=4 k ohm

应用注意: 在 VDD 和 GND 之间的 0.1uf 电容, 在 PCB LAYOUT 时, 最好要贴著 IC 的 PIN,这样可以提高 IC 的干扰能力

## 48-pin ssop (300mil) Outline Dimensions

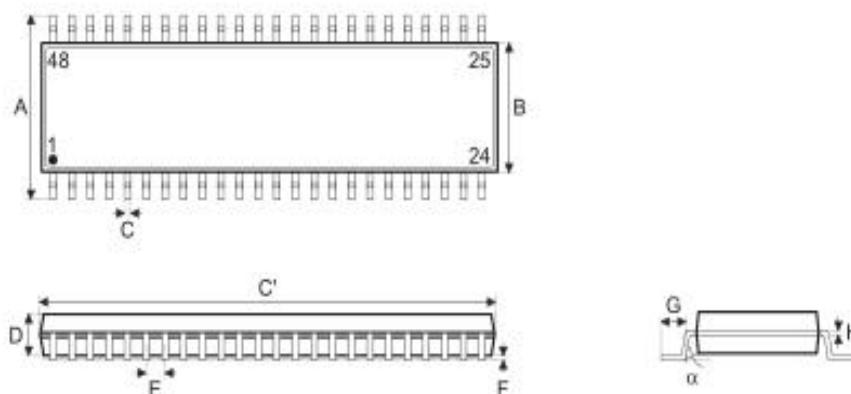

Symbol	Dimensions in inch		
	Min	Nom	Max
A	0.395	—	0.420
B	0.291	—	0.299
C	0.008	—	0.012
C'	0.613	—	0.637
D	0.085	—	0.099
E	—	0.025	—
F	0.004	—	0.010
G	0.025	—	0.035
H	0.004	—	0.012
a	0°	—	8°

Symbol	Dimensions in mm		
	Min	Nom	Max
A	10.03	—	10.67
B	7.39	—	7.59
C	0.20	—	0.30
C'	15.57	—	16.18
D	2.16	—	2.51
E	—	0.64	—
F	0.10	—	0.25
G	0.64	—	0.89
H	0.10	—	0.30
a	0°	—	8°

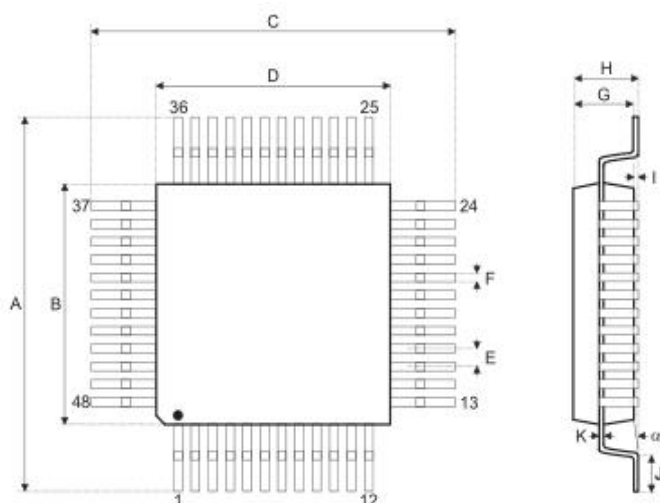
**48-pin LQFP (7mm×7mm) Outline Dimensions**

Symbol	Dimensions in inch		
	Min	Nom	Max
A	0.350	—	0.358
B	0.272	—	0.280
C	0.350	—	0.358
D	0.272	—	0.280
E	—	0.020	—
F	—	0.008	—
G	0.053	—	0.057
H	—	—	0.063
I	—	0.004	—
J	0.018	—	0.030
K	0.004	—	0.008
a	0°	—	7°

Symbol	Dimensions in mm		
	Min	Nom	Max
A	8.90	—	9.10
B	6.90	—	7.10
C	8.90	—	9.10
D	6.90	—	7.10
E	—	0.50	—
F	—	0.20	—
G	1.35	—	1.45
H	—	—	1.60
I	—	0.10	—
J	0.45	—	0.75
K	0.10	—	0.20
a	0°	—	7°

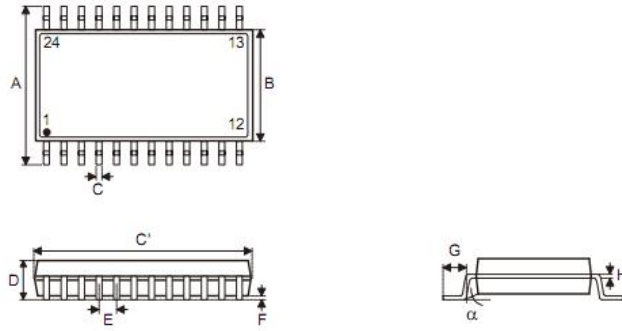
**24-pin SOP (300mil) Outline Dimensions**

Symbol	Dimensions in inch		
	Min.	Nom.	Max.
A	—	0.406 BSC	—
B	—	0.295 BSC	—
C	0.012	—	0.020
C'	—	0.606 BSC	—
D	—	—	0.104
E	—	0.050 BSC	—
F	0.004	—	0.012
G	0.016	—	0.050
H	0.008	—	0.013
$\alpha$	0°	—	8°

Symbol	Dimensions in mm		
	Min.	Nom.	Max.
A	—	10.30 BSC	—
B	—	7.5 BSC	—
C	0.31	—	0.51
C'	—	15.4 BSC	—
D	—	—	2.65
E	—	1.27 BSC	—
F	0.10	—	0.30
G	0.40	—	1.27
H	0.20	—	0.33
$\alpha$	0°	—	8°

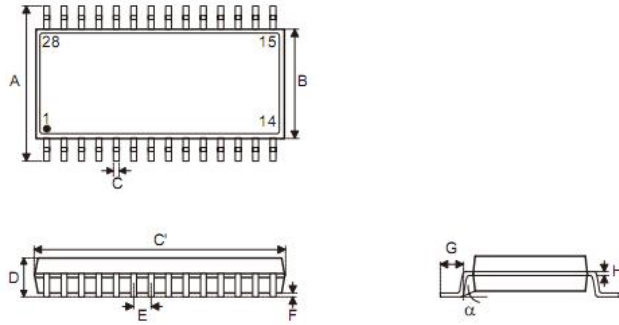

**28-pin SOP (300mil) Outline Dimensions**

Symbol	Dimensions in inch		
	Min.	Nom.	Max.
A	—	0.406 BSC	—
B	—	0.295 BSC	—
C	0.012	—	0.020
C'	—	0.705 BSC	—
D	—	—	0.104
E	—	0.050 BSC	—
F	0.004	—	0.012
G	0.016	—	0.050
H	0.008	—	0.013
$\alpha$	0°	—	8°

Symbol	Dimensions in mm		
	Min.	Nom.	Max.
A	—	10.30 BSC	—
B	—	7.5 BSC	—
C	0.31	—	0.51
C'	—	17.9 BSC	—
D	—	—	2.65
E	—	1.27 BSC	—
F	0.10	—	0.30
G	0.40	—	1.27
H	0.20	—	0.33
$\alpha$	0°	—	8°